

---

**CONVEX**  
**Service Plan for ATL Products**  
**ACL2640 Automated**  
**Tape Library (DTL)**

---



First Edition  
May 1994

CONVEX Press  
Richardson, Texas  
United States of America



CONVEX

cc: Jerry, Gent, Ronel  
+  
Hann, ...  
Thomson

FACSIMILE  
FOR IMMEDIATE DELIVERY

TO: JAN VANKATS  
COMPANY: CONVEX  
LOCATION: THE NETHERLANDS  
FROM: Wm. L. Lippa  
COPY TO: \_\_\_\_\_

DATE: 7/5/94

1 OF PAGES SENT  
(INCLUDING THIS  
HEADER PAGE) 24

CONVEX COMPUTER CORPORATION  
3000 WATERVIEW PARKWAY  
RICHARDSON, TEXAS 75083  
(214) 497-4000

SEND FACSIMILES TO (214) 497-4770 (auto-answer)  
TO VERIFY RECEIPT, CALL (214) 497-4297 (BONNIE WISLEY)

THIS MESSAGE SENT TO FACSIMILE TELEPHONE #: 31-30-892942

SUBJECT: DLT Service PLAN

MESSAGE: \_\_\_\_\_

PER YOUR REQUEST - HARD COPY TO FOLLOW

---

**CONVEX**  
**Service Plan for ATL Products ACL 2640 Automated**  
**Tape Library (DTL)**

Copyright © 1994 CONVEX Computer Corporation  
All rights reserved.

This document is copyrighted. This document may not, in whole or part, be copied, duplicated, reproduced, translated, electronically stored, or reduced to machine readable form without prior written consent from CONVEX Computer Corporation.

Although the material contained herein has been carefully reviewed, CONVEX Computer Corporation does not warrant it to be free of errors or omissions. CONVEX reserves the right to make corrections, updates, revisions or changes to the information contained herein. CONVEX does not warrant the material described herein to be free of patent infringement.

CONVEX and the CONVEX logo ("C") are registered trademarks of CONVEX Computer Corporation.

UNIX is a registered trademark of UNIX System Laboratories, Inc., a wholly owned subsidiary of Novell, Inc.

FileServ is a registered trademark of E-Systems, Inc.

Univision is a registered trademark of Open Vision Technologies.

 This book is recyclable.

Printed in the United States of America

---

**Revision information for**

**CONVEX**

**Service Plan for ATL Products ACL-2640 Automated Tape  
Library (DTL)**

---

<b>Edition</b>	<b>Document No.</b>	<b>Description</b>
First	081-025130-000	Initial release May, 1994

---

# Contents

Product information .....	1
Technical and performance information .....	1
Digital linear tape and the DEC DLT2000 .....	2
Multi-unit library configurations .....	2
Equipment specification .....	4
Facility and clearance requirements .....	5
Required cables .....	8
MTBF .....	8
System software requirements .....	9
C-Series software .....	9
Software distribution options .....	10
Service philosophy .....	11
Spare parts .....	11
Maintenance .....	13
Level of repair .....	13
Diagnostic approach .....	13
Preventive maintenance schedule .....	14
Recommended tools .....	15
Service manuals .....	17
Installation .....	18
Support .....	18
Obtaining spares and tools .....	18
Training .....	19

---

# Service Plan for ATL Products ACL2640 Automated Tape Library (DLT)

CONVEX now offers the ATL Products ACL2640 automated tape library. The ACL2640 provides data archival and backup capability using high-performance robotics and three DEC DLT2000 cartridge tape drives.

The ACL2640 can be connected to the Hewlett-Packard workstations or CONVEX C-Series platforms both using Unitree data management software.

This document provides the service manager advanced information about the ACL2640 for planning purposes.

---

## Product information

The ACL2640 is a computer-controlled, random-access tape library. The ACL2640 holds up to 264 cartridges and offers a maximum data storage capability of 2.64 Terabytes without data compression and 5.28 Terabytes with data compression (assuming a 2:1 compression ratio). The ACL2640 is a mid-range computer peripheral for distributed processing and network server environments.

---

## Technical and performance information

The ACL2640 consists of these components:

- Tape drives—three DEC DLT2000s
- Import/export device (IOD)—allows transferring single cartridges in and out of the library.
- Barcode scanner—reads the tape barcode to maintain the directory.
- Multi-unit controller (MUC)—provides communications between the host computer and the library via a SCSI interface. It converts the SCSI command set to the ACL2640's native RS232C interface. It allows up to four additional library units in a single configuration.

- Pass-through mechanism (PTM)—permits the transfer of cartridges between the IOD and the ACL2640 and among the units in a multi-unit configuration.

The ACL2640 may be integrated into multi-unit configurations which use up to five library units.

#### **Digital linear tape and the DEC DLT2000**

The digital linear tape DLT-2 format uses two read and two write heads. It uses 128 tracks in 64 pairs and writes in a serpentine fashion.

The DEC DTL2000 is a 0.5-inch cartridge streaming tape drive. The cartridge uses 0.5-mil thick tape. Each cartridge can store to 10 GBytes without data compression or up to 20 GBytes with compression. The drive has a SCSI-2 interface which can transfer data to/from the host at a maximum burst rate of 5 MBytes/sec. The drive, however, transfers data to/from its internal buffer to the tape at a continuous rate of 1.25 MBytes/sec. The rate doubles to 2.5MBytes/sec when a 2:1 data compression algorithm is used.

#### **Multi-unit library configurations**

The ACL2640 library unit may be integrated into library configurations of one to five units. A multi-unit configuration will contain at least one library unit (referred to as *unit 0*) with an MUC. The IOD is mounted on the left side of this unit (for both single- and multi-unit configurations). Additional library units are referred to as units 1 - 4, respectively. Unit 1 connects to unit 0 on the right side of unit 0 (the side opposite the IOD). Each additional library unit connects to the lower-numbered unit in this manner and contains a PTM that moves cartridges between library units (unit 0 also has a PTM).

The host computer controls all library units (robotics) in the configuration by a single SCSI interface via the MUC. The MUC converts the SCSI command set and interface into the serial interface required by robotics. Figure 1 shows the robotics control flow. The serial interface is distributed to each library unit by an RS232 distributor in unit 0.

Figure 1 SCSI-to-RS232 control distribution

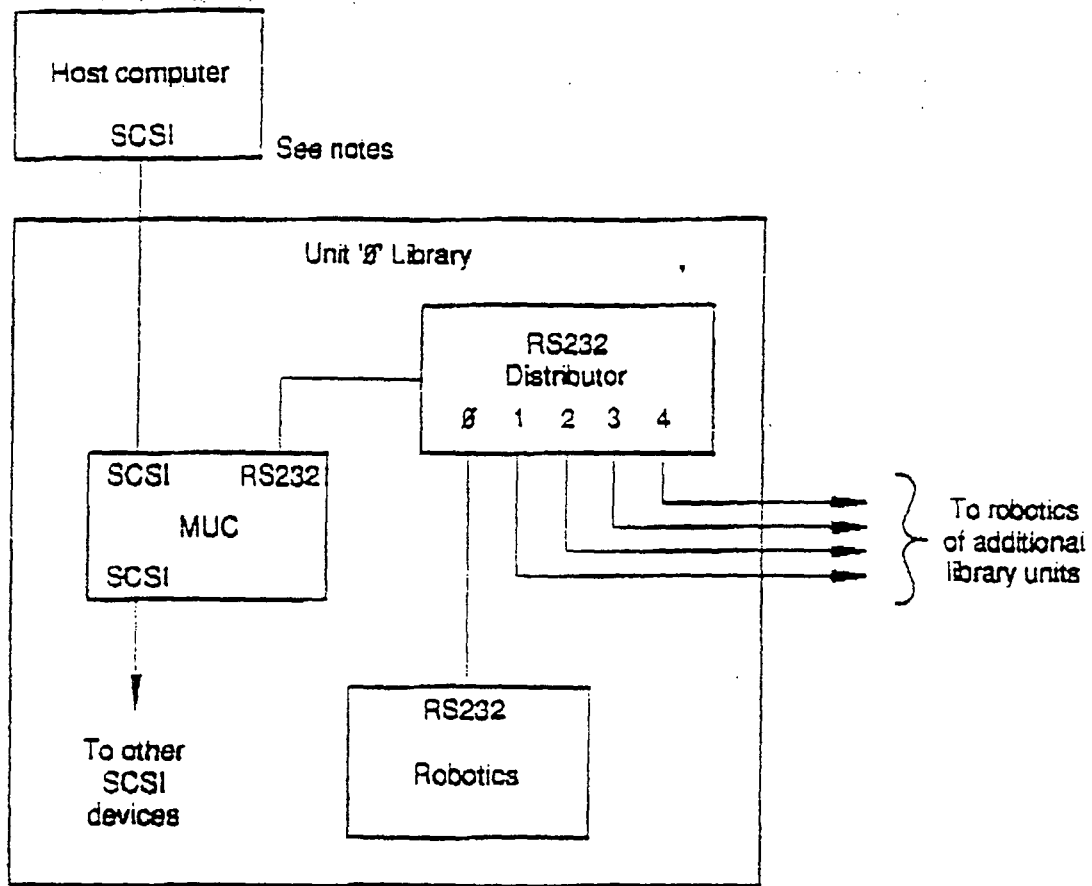

Notes:

For C-Series platforms, the SCSI interface is a Rimfire 3516 over two buses (Ref Convex P/N 220-000019-200).

For HP platforms, the SCSI interface is a Slow/Narrow/Differential over two buses.

ODE-02  
8/22/94

### Equipment specification

Table 1 shows the equipment specifications of the ACL2640

Table 1 ACL2640 specifications

Cartridge capacity	264
Tape drive capacity	3
Host computer interface	SCSI, Slow/Narrow/Differential
Average cartridge move time within unit	15 seconds
Average unit-to-unit pass-through time	4 seconds
Average cartridge input time	30 seconds
Average cartridge output time	20 seconds
Mean swaps per hour	160
Operating temperature	59°F to 90°F (15°C to 32°C)
Power consumption (maximum)	800 VA (with 3 drives)
Weight with 3 drives	935 lb (425 kg)
Weight, fully loaded (264 cassettes)	1,067 lb. (485 kg)
Height	79in (201 cm)
Width	28.25 in (72 cm)
Depth	47 in (120 cm)

### **Facility and clearance requirements**

The ACL2640 requires a room large enough for storage operation and maintenance. These requirements are detailed in this section.

### **Floor type, loading and clearances**

Any type floor is acceptable provided they meet the following requirements:

- The floor must be level and capable of supporting the weight of the particular configuration (single- or multi-unit)
- Carpeted flooring has antistatic mats for each library unit with minimum service area.
- The cabinet has a nominal floor clearance of 0.75 inches. Therefore, if you plan to install the cabinet in a carpeted area, allow adequate air flow for carpet compressing under the leveling feet.

The floor must be able to support the full weight of a loaded cabinet. For planning purposes, the combined weight includes the following:

- Library w/ three tape drives      935 lb. (425 kg)
- Tape cartridges                      132 lb. (60 kg)

Figure 2 shows dimensions of the ACL2640, allowing site administrators to plan for doorway clearance and service area. The ceiling of the operations room must be at least eight feet.

Figure 2 ACL2640 outline dimensions

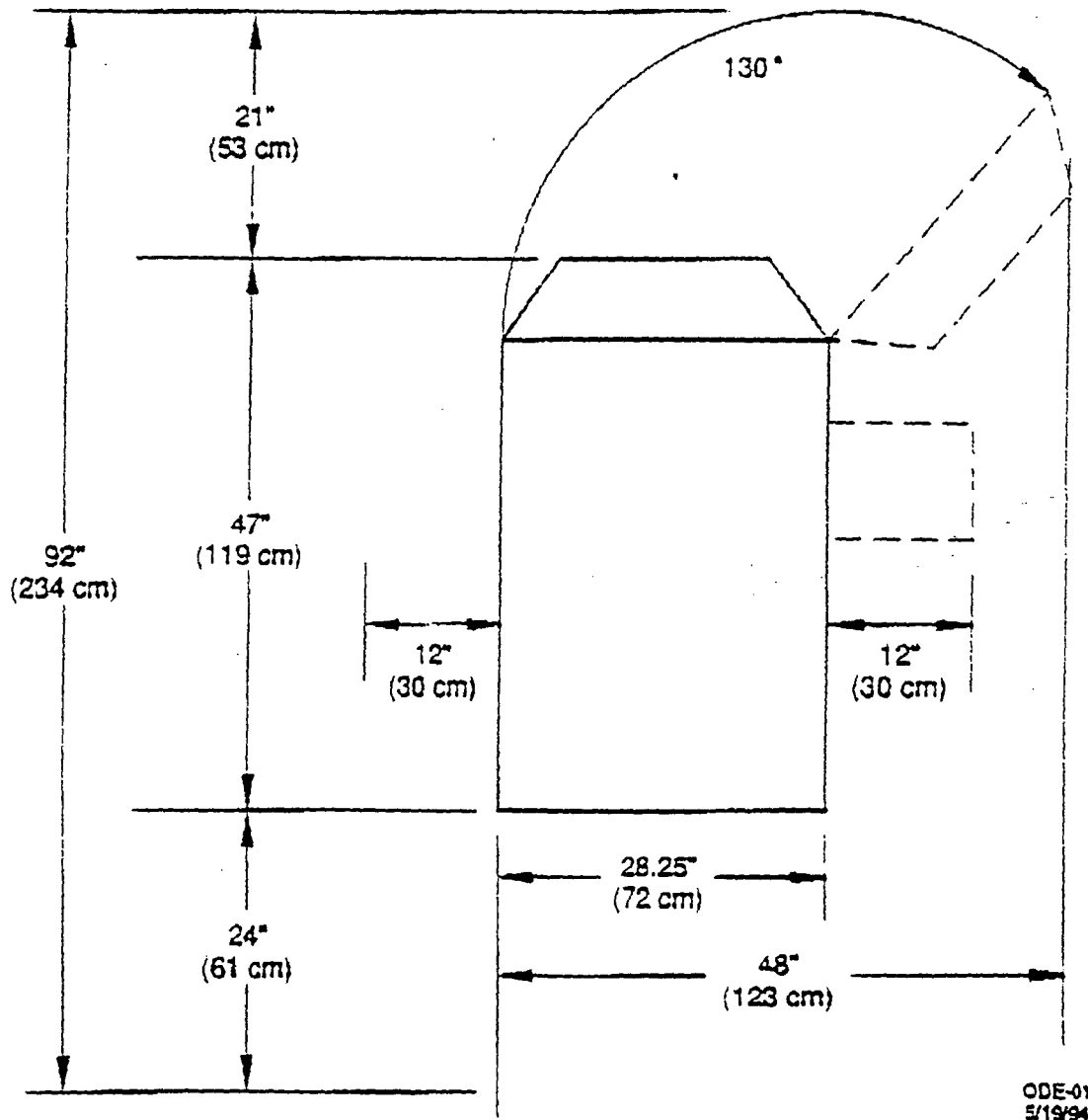

#### Power requirements

The ACL260 AC power requirements for a single-unit configuration with an IOD and three tape drives is ~120 vac, 10A, 60Hz nominal or ~230vac, 5A, 50Hz nominal.

The ACL2640 uses an autoranging power supply that accepts either 90 to 132 vac or 175 to 264 vac, single phase, 47 to 63 Hz. The cooling fan power supply is not autoranging and must be manually set. The power consumption for a single ACL2640 and three tape drives is shown in Table 2.

The ACL2640 is shipped with an IEC-320 connector. For the type power cord required in your region follow the local electrical codes and order the connector locally.

The unit does not supply spike suppression or power factor correction and needs to be connected to a power bus that has no equipment connected that requires a large inrush current.

Clearly mark the service for electrical hazards, and provide a shunt trip for emergency power off.

#### Environmental requirements

Table 2 shows the environmental requirements of the ACL2640.

Table 2 ACL2640 environmental requirements

Operational temperature	59°F to 90°F (15°C to 32°C)
Non-operational temperature	-40°F to 151°F (-40°C to 66°C)
Operational thermal transition	±20°F (±11°C) per hour
Non-operational thermal transition	±54°F (±30°C) per hour
Operational humidity	30% to 85%, non-condensing
Non-operational humidity	5% to 95%, non-condensing
Operational altitude	8,000 feet (2,400 meters) maximum
Non-operational altitude	14,000 feet (4,300 meters) maximum

Do not install the ACL2640 next to equipment that radiates excessive radio frequency interference.

**Required cables**

The ACL2640 uses two SCSI cables between the *host* and the *library*. One SCSI cable connects two tape drives to the host computer and the other connects the third drive and the MUC to the host computer. The SCSI interface is a Slow/Narrow/Differential that allows a maximum data transfer between the host and the tape drives of 5 MBytes/sec. The SCSI cable are 50-pin centronics on the library side.

An RS232C serial interface cable is required to connect the host computer to the ACL2640 diagnostic port.

**Connector requirements**

The ACL2640 is shipped with the following connectors:

- SCSI II                    50-pin centronics female
- Diagnostic port        9-pin EIA/TIA-574 female
- Power                    IEC 320 male

**MTBF**

The mean-time-between-failures for the ACL2640 with all three drives is defined for light, medium, and heavy duty.

Figure 3 MTBF for ACL2640

Work load	Definition	MTBF (hours)
Light	10 swaps per hour, 10% duty cycle on the drives	18,500
Medium	40 swaps per hour, 15% duty cycle on the drives	12,300
Heavy	80 swaps per hour, 20% duty cycle on the drives	9,000

---

### System software requirements

The ACL2640 may be used on CONVEX C-Series and HP 735/755 systems.

#### C-Series software

To use the ACL2640 on a CONVEX C-series system, the software listed in Table 3 must be installed.

Table 3 Required software for C-Series systems

CONVEX PN	Product	Description
081-006715-xxx	ConvexOS V10.1 or higher	Operating system
710-000215-011	Robot driver and DLT tape driver	SCSI pass-through portion of ANASAZI II standard ConvexOS tape driver
750-000115-006	Robot daemon	initial version (bundled with Unitree)
750-000115-xxx	Unitree V1.7.x	Data management software

#### Hewlett-Packard 735/755 software

To use the ACL2640 on the Hewlett-Packard system, the software listed in Table 4 and Table 5 must be installed.

Table 4 Required software for HP 735/755 systems

CONVEX PN	Product	Description
TBD	HP-UX v9.01	Operating system
750-002415-001	DLT tape driver	CONVEX tape driver for HP-UX (bundled with Unitree)
750-000115-006	Robot daemon	initial version (bundled with Unitree)
See Table 5	Unitree V1.7.x	Data management software

The ACL2640 requires the Hewlett-Packard HP-UX v9.01 or higher operating system (CONVEX part number to be determined) and Unitree 1.7.x data management software. Unitree software is licensed based on the amount of data stored in the system. Each installation will need the Unitree Software kit, the base license, and the LTU license.

Order Unitree software by normal sales order procedures. When ready to install the software, call the TAC for a validation key.

The part number for the basic software kit and the site license are listed in Table 5.

**Table 5 Unitree licensing**

Convex part number	System storage size
750-001522-xxx	Unitree Software Kit
750-000490-000	Unitree base license
750-000749-005	560 GBytes
750-000749-006	900 GBytes
750-000749-007	1.4 TBytes
750-000749-008	2.5 TBytes
750-000749-009	5 TBytes
750-000749-010	10 TBytes
750-000749-011	50 TBytes
750-000749-012	100 TBytes
750-000749-013	500 TBytes
750-000749-014	1,000 TBytes
750-000749-015	5,000 TBytes
750-000749-016	10,000 TBytes
750-000749-200	Source LTU

Future plans may include the use of the Hewlett-Packard 800 series computers as a customer-independent sourcing selection. At this time, CONVEX does not plan to sell nor provide service for the HP800 series products. The customer must contract service directly from Hewlett-Packard.

#### **Software distribution options**

For the C-Series platforms, ConvexOS, Unitree, robotics driver, and their updates and revisions will be distributed on digital audio tape (DAT)

For the HP platforms, HPUX, Unitree, robotics driver, and their updates and revisions will be distributed on compact disc read-only memory (CDROM).

The ACL2640 robotics firmware can be downloaded from a PC over the diagnostic port.

The tape drive firmware can be loaded via a DLT-2 tape.

## Service philosophy

CONVEX is the primary service provider for the ACL2640. This service consists of three levels. The first level is the response to the customer problem call. When the problem call requires corrective (or preventive) maintenance, a service engineer (SSE) is dispatched to the customer site to troubleshoot the problem. Second-level service is fixing the problem with the appropriate spare parts. Third-level service is technical backup from CONVEX headquarters. Personnel with the appropriate expertise are on standby to resolve problems with either the SSE or the customer in some cases. Service personnel require proper training, tools and spare parts before down-time can be kept within specification.

## Spare parts

Service engineers perform field preventive and corrective maintenance activities on certain components of the system. Table 6 shows these field replaceable units (FRUs).

The distribution of spares will be managed over time. The stocked spare parts list is subject to change as CONVEX gains experience.

Table 6 ACL2640 FRUs

CONVEX P/N	Description	Stocked by CONVEX	Replacement status <sup>1</sup>	MTR (minutes)
900-000990-001	Stepper motor assembly		NR	35
900-000990-002	Logic power supply	X	R	35
900-000990-003	Motor power supply	X	R	40
900-000990-004	Tape drive power supply		NR	25
900-000990-005	Rear panel interlock switch		E	10
900-000990-006	Home/limit opto-sensor		E	20
900-000990-007	DLT barcode scanner		R	25
900-000990-008	Tape drive DLT200 DE SCSI	X	R	45
900-000990-009	Fan	X	E	20
900-000990-010	AC power strip		E	15
900-000990-011	Carousel timing belt		E	20
900-000990-012	Vertical drive belt		E	50
900-000990-013	Extension axis assembly	X	R	25
900-000990-014	Control panel PWA		R	20
900-000990-015	Door interface PWA		E	15
900-000990-016	Carousel motor drive assembly	X	R	45

Table 6 ACL2640 FRUs (continued)

CONVEX P/N	Description	Stocked by CONVEX	Replacement status <sup>1</sup>	MTR (minutes)
900-000990-017	AC power distribution unit		R	40
900-000990-018	Binpack assembly		E	6
900-000990-019	Light curtain receiver PWA		NR	30
900-000990-020	RS232 Distribution PWA		R	60
900-000990-021	Front door interlock switch		E	10
900-000990-022	Robotic controller PWA	X	R	60
900-000990-023	Actuator driver PWA	X	R	60
900-000990-024	Stepper motor drive PCBA	X	R	40
900-000990-025	Umbilical cable	X	E	40
900-000990-026	Car sensor/light PWA	X	NR	25
900-000990-027	PTM tray assembly		R	80
900-000990-028	IOD assembly	X	R	50
900-000990-029	MCU assembly, differential	X	R	45
900-000990-030	Vertical motor assembly	X	NR	70

1. Replacement status codes

- E Expendable: Not serialized - Value does not justify return to ATL even during warranty period.
- R Repairable: Return to appropriate material depot for repair - serialized for warranty tracking by ATL.
- NR Non-repairable: Value justifies returning to ATL warranty period - serialized for warranty tracking by ATL.

---

## Maintenance

### Level of repair

The level of repair is determined by the local Field Support management. With training, all adjustment and cleaning can be performed by CONVEX SSEs. Failed FRUs are diagnosed and replaced by the SSE and returned to CONVEX via the logistic procedures appropriate for the region. The spares listed in Table 6 are required to adequately maintain the ACL2640. These spares will normally be stocked at the depot level.

For logistic procedures contact:

	Primary contact	Region	E-mail login	Phone number
Headquarters Spares Depot	Barbara Lester	US, S. America, Asia, and Pacific	lester	(214) 497-4216
European Distribution Center	Jorge Torres	Europe	torres	31-20-6540251 (Holland)

### Diagnostic approach

The diagnostic approach for the ATL2640 will be to:

- To inspect the library control panel located on the front door. Error codes help the operator locate failed subsystems. These same error codes are also sent to the host computer.
- To use a diagnostic computer to further troubleshoot and isolate failed FRUs. An IBM-compatible personal computer is required for running the diagnostic software. See the "Diagnostic computer" section on page 15 for the required configuration.
- Replace failed FRUs. Failed FRUs are returned to CONVEX for repair or warranty replacement, if designated in Table 6.

The diagnostic software performs six functions that are outlined as follows:

- User Test—logging of all messages to disk, entering commands in ASCII strings
- System—high-level commands that exercise hardware components
- Status—feedback from various sensors and system statistical information
- Move Actuators—low-level commands move actuators a step at a time and cartridges within the system

- **Align/Calibrate**—provides alignment of the carousel, bin slots, and tape drives
- **Configuration**—sets system configuration, initializes inventory sequence, and enables recovery capabilities.

**Preventive maintenance schedule**

Table 7 outlines periodic preventive maintenance (PM) tasks performed by both the operator and the SSE.

**Table 7** Periodic preventive maintenance schedule

<b>Procedure</b>	<b>Operator maintenance</b>	<b>SSE maintenance</b>
Clean and lubricate vertical rails	every 90 days	90 days after installation
Clean and lubricate extension rails	every 90 days	90 days after installation
Clean and lubricate the geneva mechanism inside gripper	N/A	every 180 days
Check and adjust carousel belt tension	N/A	every 180 days
Check and adjust vertical-axis belt tension	N/A	every 180 days
Check and adjust extension-axis belt tension	N/A	every 180 days
Clean fan filter	N/A	every 180 days

The SSE PM is recommended 90 days after installation and every 180 days thereafter.

**Preventive maintenance supplies**

The following supplies are recommended for routine PM clean up:

- Presaturated lint-free nonabrasive cloths
- Lubricants as defined in ACL2640 support manuals
- Prelubricated cloths
- Dry tissues
- Can of compressed air

**Head cleaning tape**

The DEC DLT2000 tape drive heads require periodic cleaning. Use the cleaning tape regularly ( CONVEX PN 900-000990-040).

### Recommended tools

The tools in the standard SSE toolkit are sufficient to maintain the ACL2640. Be sure the toolkit has a 1-3/8" open-end wrench and a 2 in-lb or better torque wrench. The tools listed in Table 8 are required in addition to those in the standard tool kit.

Table 8 Special tool

CONVEX P/N	Description
900-000990-031	DLT, alignment calibration kit
900-000990-032	DLT, force gauge, 32 oz. max
900-000990-033	DLT, force gauge, 8 oz. max

### Diagnostic computer

The ACL2640 diagnostic software executes on any IBM-compatible personal computer. The software (CONVEX PN 900-000990-039) comes on a 3.5-inch floppy diskette.

The minimum computer configuration to execute the ACL2640 diagnostic software must include the following:

- 286 processor
- 640 KBytes of memory
- 3.5-inch floppy tape drive
- RS232 serial port (EIA/TIA-574 9-pin interface)
- RS232 serial cable, 6 to 8 feet long

The following is the recommended configuration:

- 386 processor
- 2 MBytes of memory
- harddrive (software requires 270 KBytes of space)
- 3.5-inch floppy tape drive
- RS232 serial port (EIA/TIA-574 9-pin interface)
- RS232 serial cable, 6 to 8 feet long

### Supply Kit

The SSE should have access to an ATL FSI kit (CONVEX PN 900-000990-074). The components of the kit can be replaced individually, based on usage. Table 9 shows the components of the FSI kit.

Table 9 FSI kit components

CONVEX PN	Qty	Description
900-000990-043	1	SCSI terminator, 50-pin
900-000990-044	1	SCSI terminator, micro D
900-000990-045	5	Fuse, 7 A, 250 V, Motor PS
900-000990-046	5	Fuse, 3.5 A, AD F2
900-000990-047	5	Fuse, 1.6 A, AD F1
900-000990-048	5	Fuse, 160 mA, Car QSPI F2
900-000990-049	5	Fuse, .8 A, AD stepper driver
900-000990-050	5	Fuse, 1.6 A, RC F3
900-000990-051	5	Fuse, 3.15 A, AD F9
900-000990-052	5	Fuse, 2.5 A, AD F8
900-000990-053	5	Fuse, 1 A, AD IOD PTM
900-000990-054	5	Fuse, .5 A, AD F10 PTM F2
900-000990-055	5	Fuse, 315 mA, AD F4 IOD F3
900-000990-056	5	Fuse, 3 A, RC F2
900-000990-057	5	Fuse, 1 A, RC F1 step driver
900-000990-058	5	Fuse, 2 A, 250 V, Logic PS
900-000990-059	1	Switch, pushbutton, IOD
900-000990-060	5	Jumper, shunt, RCS1-S15/PTM
900-000990-061	5	Spring, Binpack
900-000990-062	5	Screw, SEM 6-32 x 1/2, Binpack
900-000990-063	3	Screw, 2-56 x 1/4, Grip cover
900-000990-064	1	Belt, timing, Ext axis
900-000990-065	5	Screw, SEM 6-32 x 5/16, Binpack
900-000990-066	5	Button, Binpack
900-000990-067	3	Sensor flag, Carousel
900-000990-068	5	Button, Binpack counterbore
900-000990-069	1	PWA, optical, TX-PTM-IOD
900-000990-070	1	PWA, optical, RX-PTM-IOD
900-000990-071	1	Spring, outport, IOD
900-000990-072	1	Sensor flag, Vertical doubler
900-000990-073	1	Sensor flag, Vertical

**Service manuals**

The manuals listed in Table 10 are available to assist the SSE to a greater level of detail.

Table 10 ACL2640 support manuals

CONVEX P/N	Title
900-000990-034	ACL2640 Field Service Manual
900-000990-035	ACL2640 Diagnostic Support User's Manual
900-000990-036	ACL2640 Operator's Guide
900-000990-037	ACL2640 Facility Planning and Installation Guide
900-000990-038	ACL2640 Software Interface Guide

---

## Installation

CONVEX field engineering organization is responsible for installing the ACL2640. It is also responsible for installing any additional units and exchanging replacement parts. These activities should be accurately recorded by field service personnel in the appropriate reporting system.

---

## Support

CONVEX is the primary service provider for the ACL2640. In the US, the CONVEX Technical Assistance Center (TAC) is the front line of support for SSEs and customers. In other CONVEX regions around the world, the SSE and customer should contact their local CONVEX support office. A second line of support is provided by expert personnel. The secondary point-of-contact for the ACL2640 is:

Point-of-contact	E-mail login	Phone number
Chris Magargee	magargee	(214) 497-4402
Kelvyn Gipp	kgipp	(214) 497-4601

### Obtaining spares and tools

When an SSE requires a spare part, he/she will follow established procedures in the appropriate region to obtain that part. Questions concerning the logistics, pricing, and ordering of spare parts and tools should be directed to:

	Primary contact	Region	E-mail login	Phone number
Headquarters Spares Depot	Barbara Lester	US, S. America, Asia, and Pacific	lester	(214) 497-4216
European Distribution Center	Jorge Torres	Europe	torres	31-20-6540251 (Holland)

---

## Training

The SSE maintaining the ACL2640 automated storage library will require training. CONVEX SSEs will attend a two-day course. The course will cover the following:

- Hardware installation
- ACL2640 alignment using ATL diagnostics
- Trouble analysis using ATL diagnostics
- Repair of the ACL2640 and the DTL2000
- Acceptance tests

The ACL2640 training class schedule for the second and third quarters of 1994 are as follows:

- July 7-8
- August 11-12

The class is offered at the Odetics Training Facility located at 1515 S. Manchester Avenue, Anaheim, California. The cost is \$800 per student. To obtain latest information for this course, contact:

Point-of-contact	E-mail login	Phone number
Debbie Ericksen	ericksen	(214) 497-4239